

CA4810A 5KV Test Fixture

Principle circuit

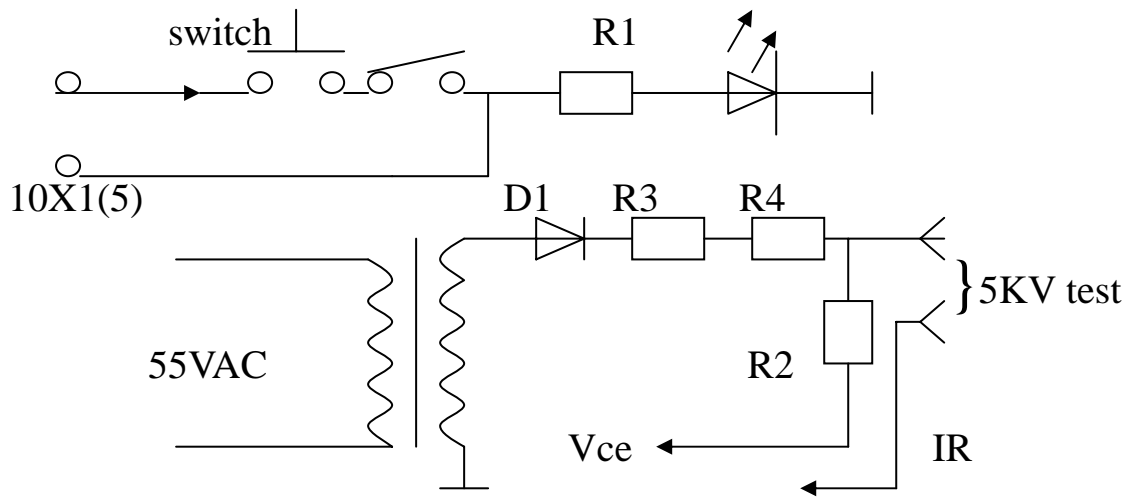

Out Look

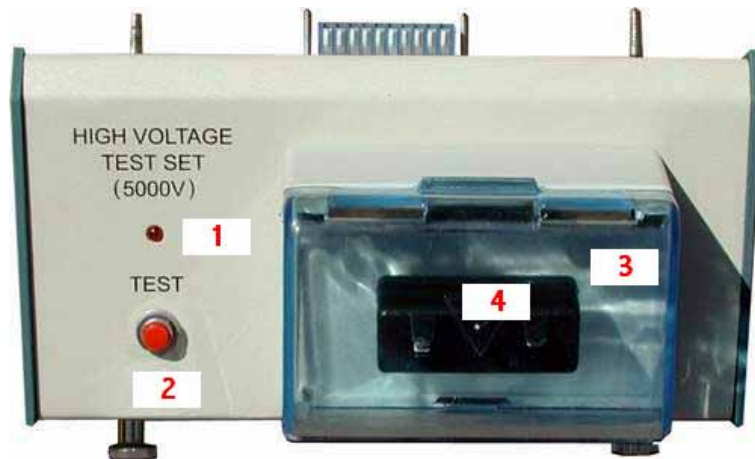

- (1) LED
- (2) Test switch
- (3) Transparent enclosure
- (4) Test socket

Main Specifications:

1. Protection transparent enclosure. The test circuit is open when the protection enclosure is open.
2. Max.test voltage: 0~5KV, adjustment in 100V/step, 200V/step, 500V/step.
3. Max.current 5mA(at test voltage 5000V).
3. 3uA balanced current

SMTmax.

<http://www.smtmax.com>