

SATC-20

SEMI-AUTOMATIC TERMINAL CRIMPING MACHINE

INSTRUCTION MANUAL



SMTmax

Introduction

Before using this machine, please read this book carefully, and make sure that you have paid enough attention to this book. By using this machine properly, you cannot only avoid accidents, but also prolong the life of the equipments. So please do give your attention to the operation. To make this machine work to its best, you should do as the below.

1. Please do read this book carefully and make sure that you have understood it well, and then you may carry on operation, maintenance as well as attendance.
2. If you want to transfer this machine to someone else, please transfer this book together.
3. Please keep this book where you can get at any moment, and put it in good condition.
4. We provide the customers with high standard service, and we have carried out “one-year maintenance and lifetime upkeep” for the all of our customers.
5. This machine has one-year guarantee (starting at the day of the assignment). During the guaranty period, if there are any problems caused by the quality, such as the machine cannot work soundly, or something abnormal happens while it is operating. Please contact with our Maintenance Department or Sales Department for instant settlement.
6. Beware that the circumstances below are beyond maintenance.
 - a) Damages caused by improper use.
 - b) Damages caused by tearing down the machine privately.
 - c) Damages caused by using the improper voltage.
 - d) Damages caused by the force majeure.
7. Exceeding 1 year limited, we will charge you proper fee for changing the wearing parts and fittings.
8. You can either deliver the machine to our factory or ask our technicians to yours for repair. And their travel expense will be count on your if the maintaining happens beyond the guaranty.
9. You can contact us through Telephone Call, FAX, E-mail so that we may provide you with satisfied service.

SAFE HANDLING

BEFORE INSTALLING:

WARNING

When hanging the machine, please confirm that the machine-ring is loose or not. If not, please fasten it. When hanging, the machine is sloped.



BEFORE OPERATING:

WARNING

1. This machine is a special tool, which can fix the terminals to the end of electronic wire. And do not use it to make pressure manufacture.
2. Can't reconstruct apparatus, transform control circuit, etc. Or else, it may cause the slipper fall two times.
3. Should not pull down the safety, the back cover or change the install parts' position.
4. Put through the ground wire, in order to keep safe.

OPERATING:

WARNING

-  Never operate the machine with the safety guard and back cover open to prevent hands and face injured.
-  Before starting motor, make sure that the top dead point go back to the correct place (where the light on the sensor is turn on, if not adjust the crankshaft until the sensor is turn on), In addition, you must take down the hand-operated rocker arm.
-  Switch off the machine, when you replace the terminals and disconnect it from the main power line before to install the applicators and servicing the

machine.

- ⚠ Regulate curly height of terminal, must disconnect power, and do not touch cutter directly to take care.
- ⚠ If two RAM phenomena take place while operating, Should stop operating immediately, and improve dealing with it.
- ⚠ While removing the waste material in the cutter, must disconnect the power, must use the manual tool to remove.

MAINTENANCE

DANGEROUS

Should pay special attention: When handle, Can't pull down and touch the control circuit, Otherwise have danger of getting an electric shock.

WARN

When just finishing the work, The temperature of the motor is still quite high, So should notice that don't touch with hands.

NOTICE

In case of assistance on the electronic parts of the machine control to disconnect the machine from the power supply line and waiting 10 minutes after the led power is switching off before to remove the electrical box cover or operate on the clamps.

Hear belts and take the wheel to grit sound in the starter motor, Please adjust the elasticity of the belt in time.

Specifications

model	SATC-20
pressure	1.96Kn
measurement	290(W)×400(L)×500(H)
movement	30mm
length of stroke	275SPM 50/60Hz
voltage	AC100V 50/60Hz
motor	220V 200W 4P
weigh	113kg

Figuration drawing

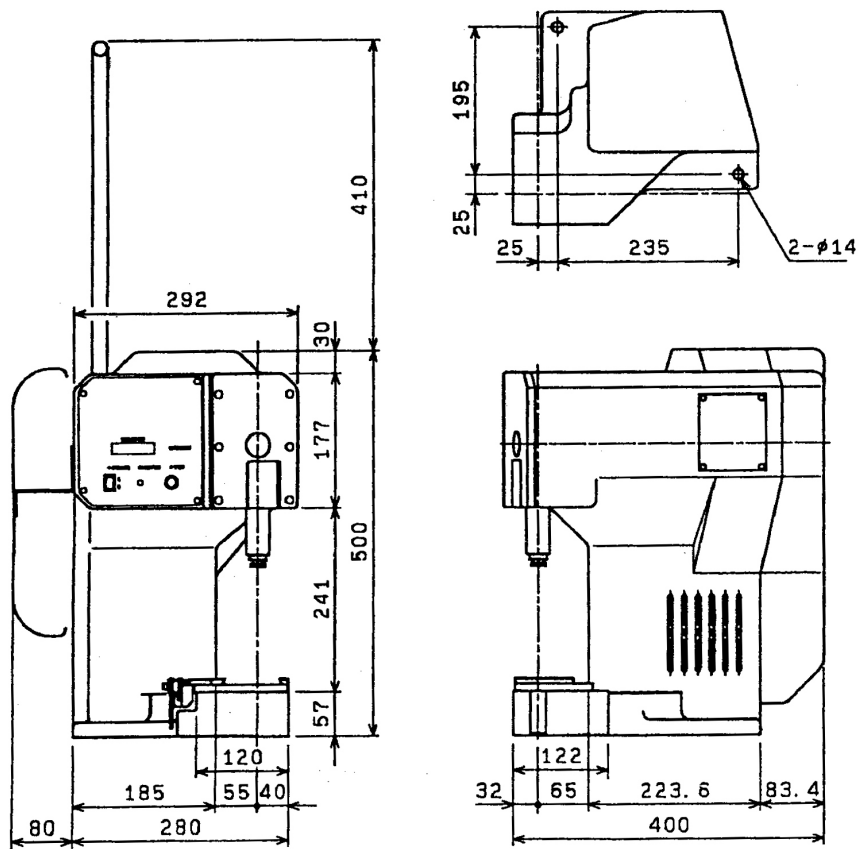

INSTALLATION

1. Please lay the machine on a fastness and horizontal bench.
2. Please confirm that the switch is OFF and then does the following equipment work.

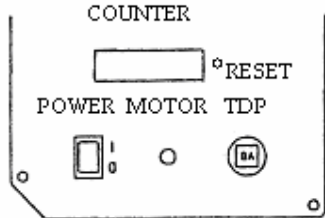

FRONT PANEL

1> The power cord connected the metal connector “POWER” on the left side of the mainframe

⚠ **Notice:** Please don't connect the plug with power before connected the cord to the mainframe.

2> The cord of foot switch is connected to “FOOT SW” on Metal connector.

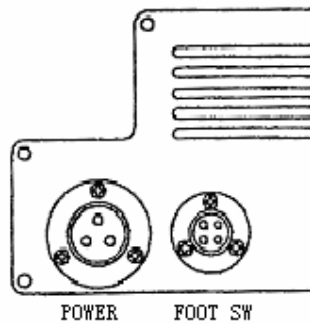

SIDE OF THE LEFT

3> Please confirm whether there are barriers under RAM.

4> Insert hand-operated rocker arm in crankshaft in front of or in the back of the machine, Aim the mark of CRAN-KSHAFT at board STOP ZONE of the back while installing. This is to start-position.

⚠ **Notice:**

If the light on the sensor is turn off, the motor will not running.

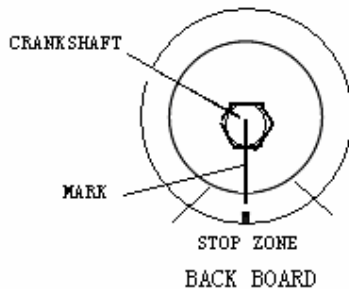

5> Turn on Power, And put through the Motor, which begin to run (Press again the Motor will Stop).When the motor is running, please check whether there are barriers under RAM, if not and then Step on the Foot Switch. RAM will do a upper and lower movement, The counter is counted one time.

3. When the mark on “CRANK SHAFT” of the machine stops outside “STOP ZONE”, the Motor will stop. The Stopping-position of a turnover of the machine is to aim at the adjustment of carrying on 50HZ. When the 60Hz area is used, please change the small diameter axle into the Motorized Pulley, and then startup. Even so, the mark on CRANK SHAFT of the machine may stops outside, STOP ZONE, Please take down METAL CONNECTOR PANEL of the left side of the machine, and adjust the stopping-position with the knob of the control device.

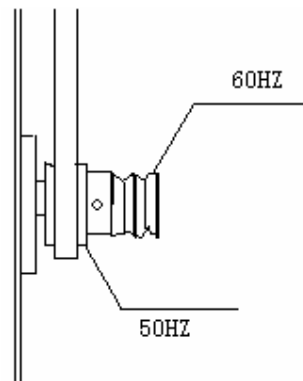

Replacement and Adjustment

1. Change Motorized Pulley

- I : Please loosen the M6 bolt, which hold the Motor on left of the machine.
- II : Please loosen the screw which hold the Motorized Pulley and change the direction of Pulley, Tighten the screw on the Motor Shaft.
- III: Installation the belt, and make the Belt inflexible on the Motor.

2> Regulate the amplitude which control the stopping-position

Rotate the amplitude towards A; The Stop Zone will skew towards A. So please regulate the amplitude. And make the Mark on the Stop Zone. Before restart the motor please wrenching the Stop Zone by hand-operated rocker arm.

Regulate the amplitude which stops the position

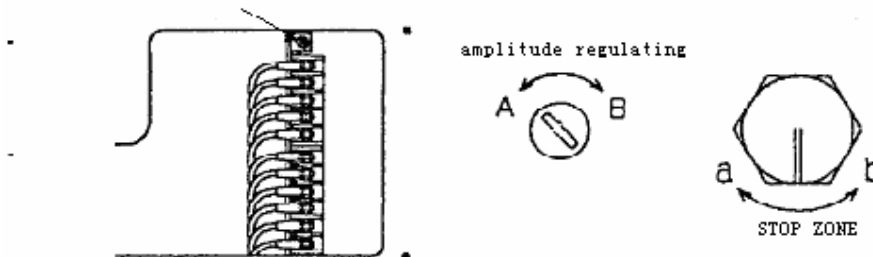

4. When you can't suit well to the height of pressing which accord with the wire, Please loosen two bolts (M6) on the RAM and Regulate the Bolt. (Rotate a scale and can regulate 0.05mm fluctuate each time, WHICH ONLY CONSULT)

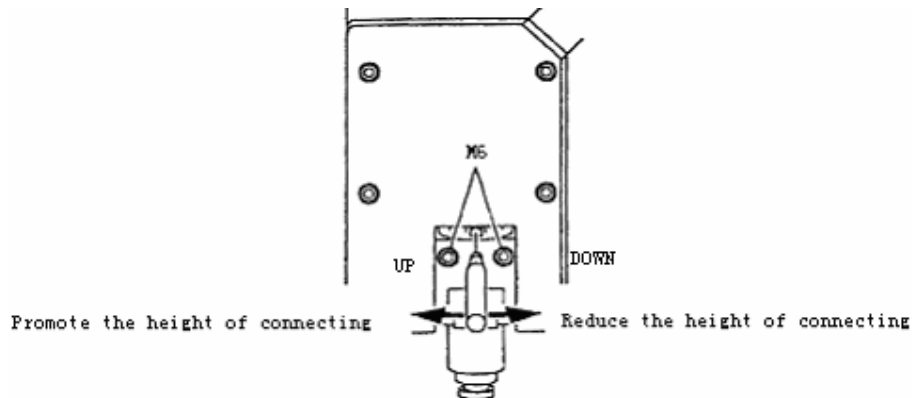

NOTICE:

- 1> In the course of operating, if the power is not turn off, do not touch the Crankshaft by hands.
- 2> Can't carry on the POWER ON-OFF within 2 seconds.

MAINTENANCE

1. GREASE:

If the lubricant is not enough, that not only shorten mechanical lifetime, but also will damage the spare part, So lubricating every 1~2 month.. Please lubricate the grease nipple of the RAM From the spray nuzzles on top of machine.

⚠ NOTICE

DON'T LUBRICATE THE CLEARANCE BETWEEN CLUTCH AND BRAKE.

2. THE CLEARANCE OF CLUTCH AND BRAKE

The clearance of CLUTCH AND BRAKE will become bigger gradually through wearing and tearing.

The clearance will become bigger the noise while increasing, sometimes cause the machine to quit work. So when periodic check, please pay attention to the clearance.

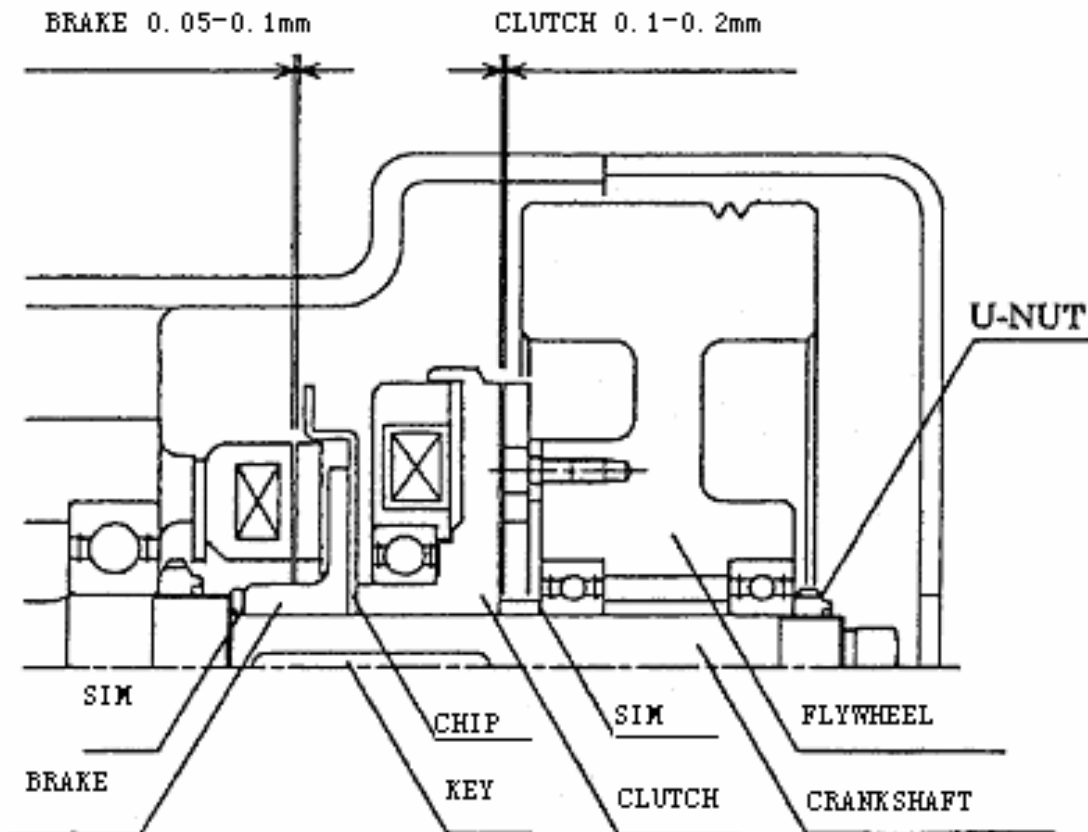

While deviating beyond the index, please regulating according to the following step:

I : Loosen the screw which holds the Motor on the left of frame and debus the V-belt
(No.39)

II : Debus the U-UNT (No.38), Draw FLYWHEEL (No.25) forward and Pull out with both
hands.

3: Debus the Collar (No.29), Clutch (No.40), Chip (No.27), Brake (No.41) and from
Crankshaft take out the Key (No.22)

Notice: While Pull out the Chip, Please Don't damages the Photo Sensor (No.42)

4: Debus a collar which adjusting the Brake, and insert the Brake in the Crankshaft,
Confirm the Clearance under press station.

Consult: The Gasket is 0.1mm (2-3 PCS)

5: If the clearance of Brake is fit, please debus the Brake again, Press KEY in CRANKSHAFT.

And in turn of Brake, Chip, Clutch, Collar to insert the Crankshaft, Decrease a Gasket of the Clutch.

Notice: When install the Clutch, Put the Stop Blocking of Clutch to POST (No.31)

6: When Installing the Flywheel; please confirm the clearance of Clutch.

If the Clearance is fit, the U-NUT should be fixed, set the V-BELT, Fix the Motor.

CIRCUIT DIAGRAM

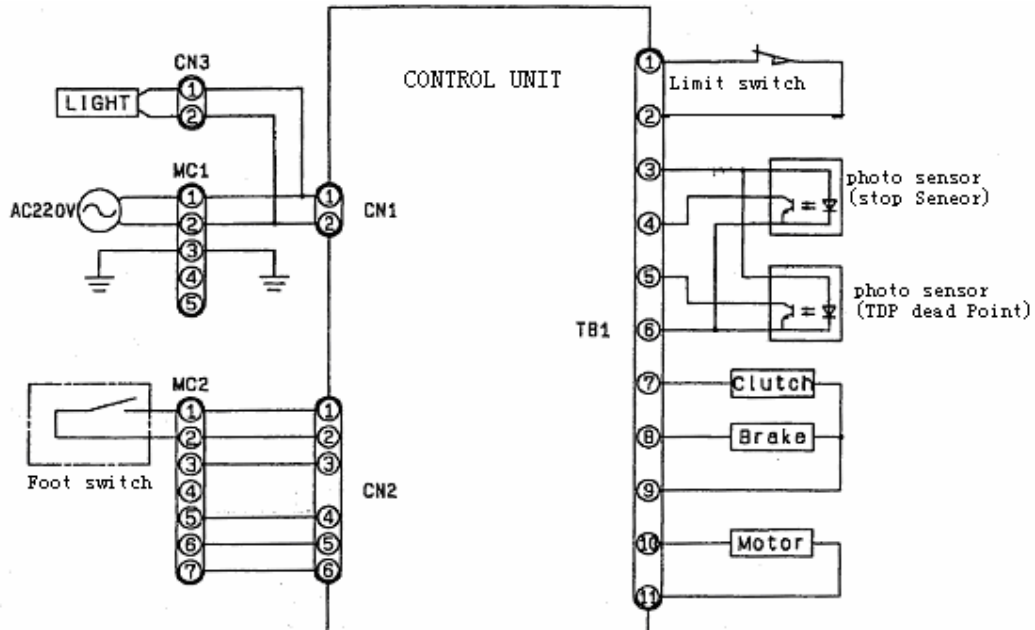

The stopping sensor also means the counting sensor, which control the modules movements.

FRAGIABLE PARTS

No.	Model	Description	Quantity	Instead Cycle
20	T-01	spring	1	6000 Hours
34	T-02	bearing	3	10000 Hours
38	T-03	v-belt	1	10000 Hours
39	T-04	clutch	1	6000 Hours
40	T-05	Brake	1	6000 Hours

Instruction drawing

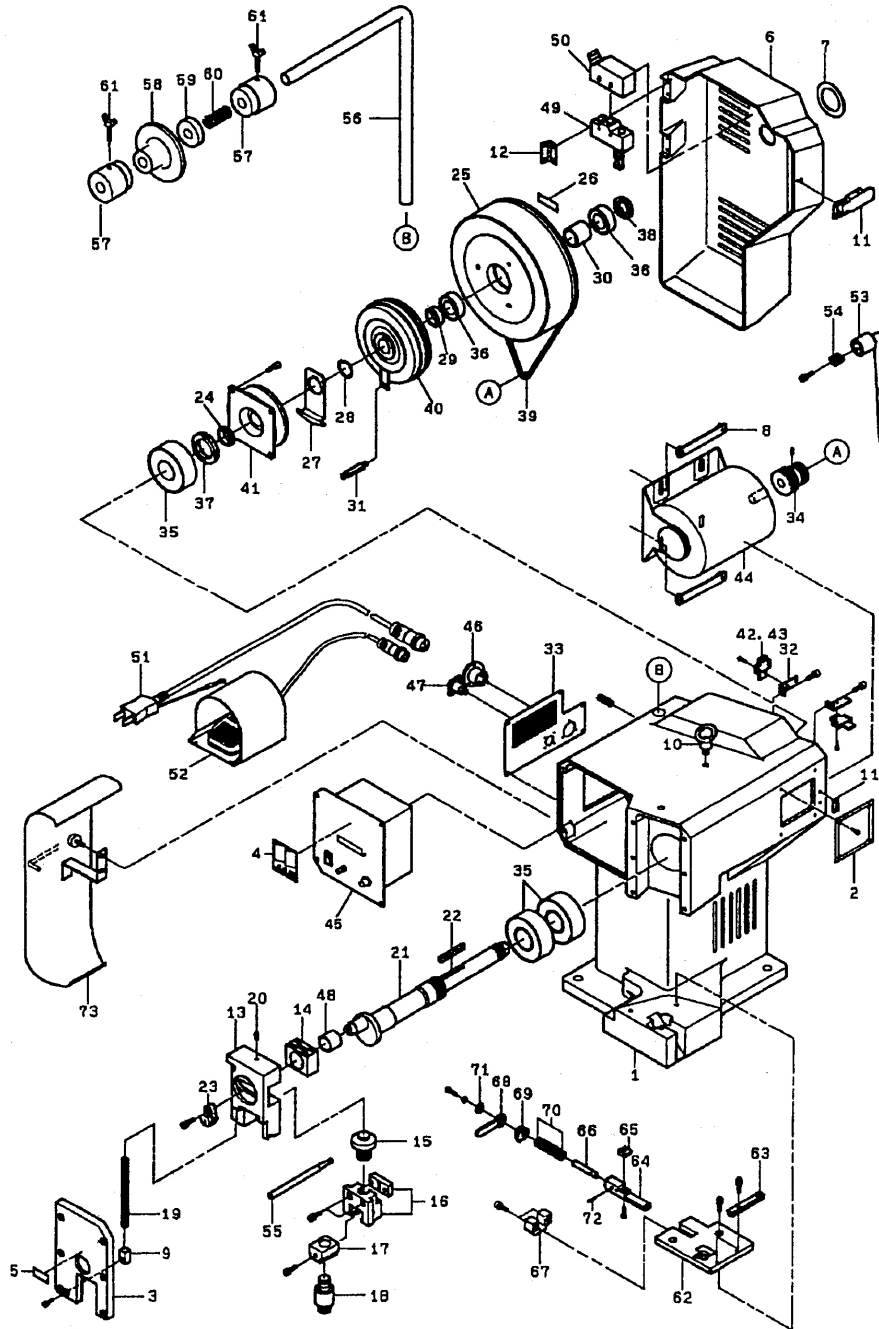

SETTING ERROR

1. Motor cannot start

1>If the light of Power is not bright, check the Breaker turn off,

2> If the light on the sensor is off, adjust the mark of CRANKSHAFT to board STOP ZONE of the back while installing.

2. During working the motor cannot run

1> The CRANKSHAFT stops at back of the Stop Zone.

Regulate the clearance of Clutch and Brake.

2>The Crankshaft stops in front of the Stop Zone.

Check the over loading (RAM worked 2 times)

Spring disrepair of No.19

Take out the both (M5) below Cover and change the spring.

The RAM is short of grease

Please grease, Substitute some parts when need and grease.

V-BELT flab

Adjust the senility of V-BELT, Looseness the 4 pcs of Bolt (M6) and regulate the motor

3. Make a unusual sound.

1>There is blob at Clutch and Brake.

2>V-BELT flab

Adjust the senility of V-BELT.

APPLICATOR INSTALLATION

Please follow for a safe and correct installation the following instructions:

1. Pull the LEVER of Simple base. After loosening the lock of the LEVER, The side pulls out left.
2. The End Feed applicator installation, Insert the pole of Applicator in RAM BOLT behind, install on the BASE.

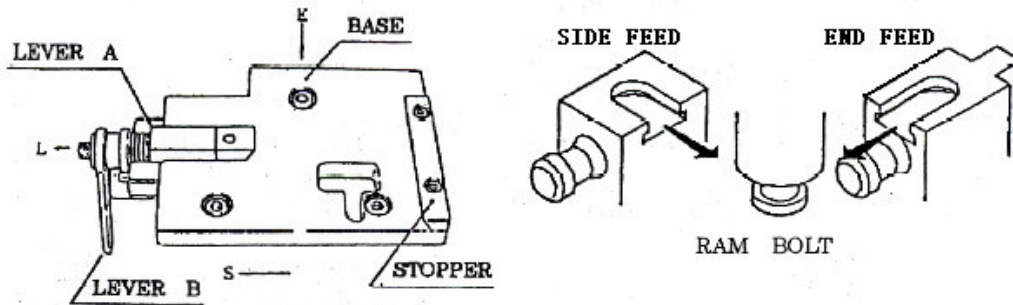

3. Pull the applicator to the STOPPER of Base, insert the Lever, and Rotate below for lock. Confirm that the applicator is not rocked.
4. Insert the hand-operated rocker arm to Crankshaft, and Rotate the hand-operated rocker arm
5. Unload the applicator, loose the lock of Lever and pull out it left, take out the applicator from rear(End Feed)or from left(Side Feed).

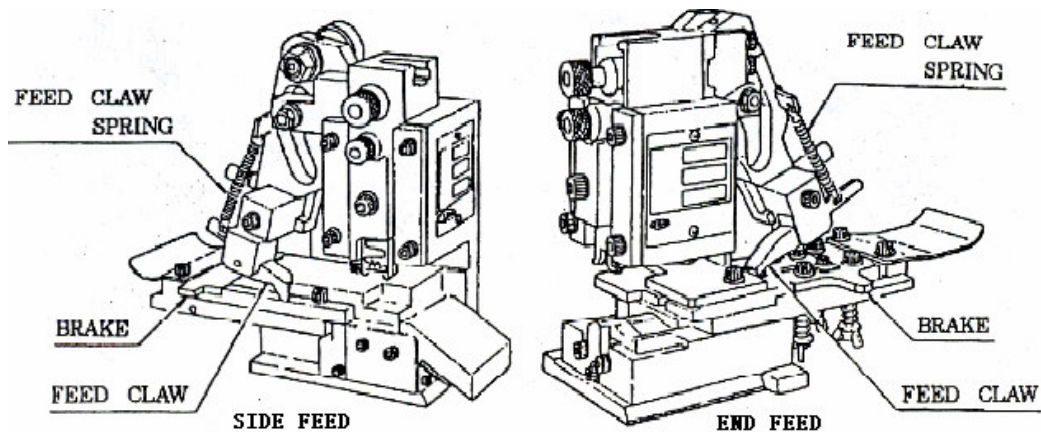

TERMINAL INSTALLATION

Please follow for a safe and correct installation the following instructions

1. Insert the REEL STAND to the hole on top of machine; fix the Reel Stand by the left Stopper

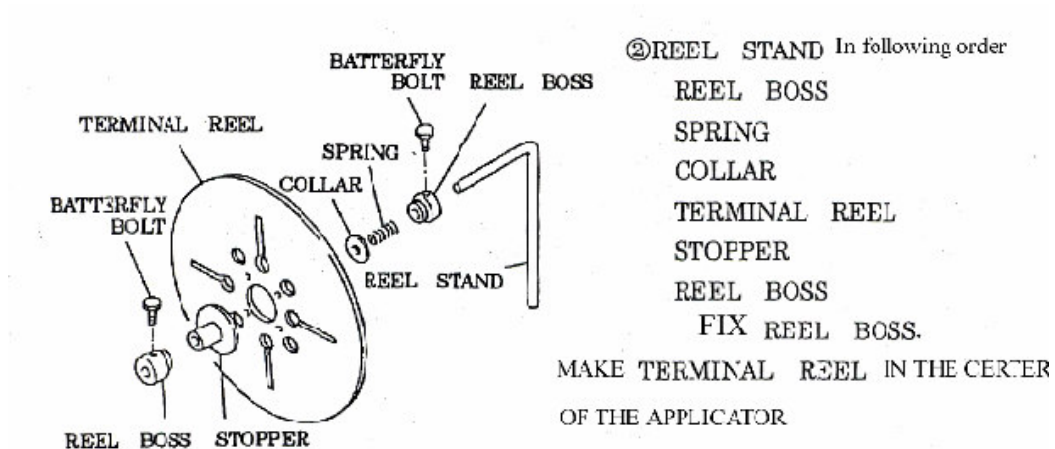

2. Insert the terminal in applicator from rear or left, raise the Brake and Feed Claw while send the first terminal to anvil.

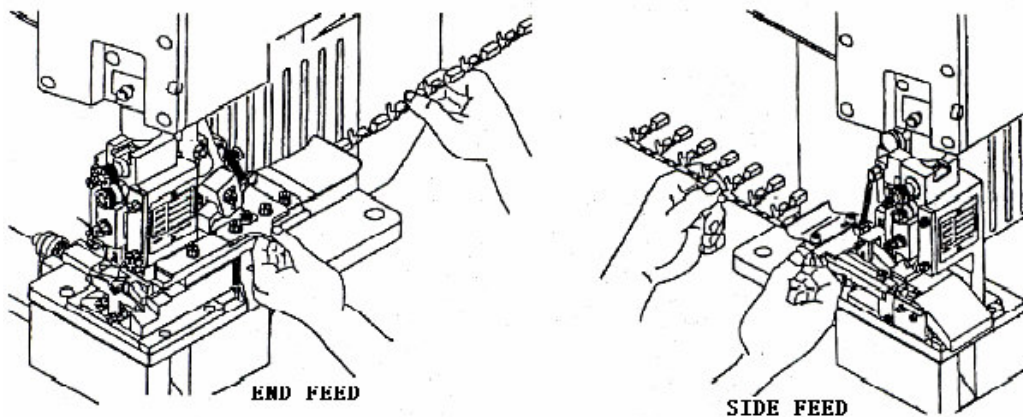

3. Lower the Brake and Feed Claw; Draw the terminal to the reverse direction for right position.
4. Unload the terminal, the handle is same as ③ raise the Brake and Feed Claw while draw it to the reverse direction.

REGULATE APPLICATOR

1. Adjusting the height of pressing of the core wire.

Please follow for a safe and correct regulate the following instructions:

Instruction of crimp height dial

- 1> There are 0~ 9 numbers signed on the crimp.
- 2> Raise one figure each time, core wire highly heighten 0.05mm pressing.

- ① Applicator regard the Crimp height dial “2” as the standard, which is suitable for the small wire. Please confirm whether the crimp height dial is “9” that is raise the height of pressing of the core wire, avoid the knives is broken while regulation.
- ② When revolve the Crankshaft for press, please confirm the knife has not touch.
- ③ In order to aim at the height of pressing of the core wire, lower the scale sequentially by “9”. Regulate the proper height according to the wire. When change the height of pressing of the core wire, pull out the crimp height dial for adjust the dial and push it to the slot.

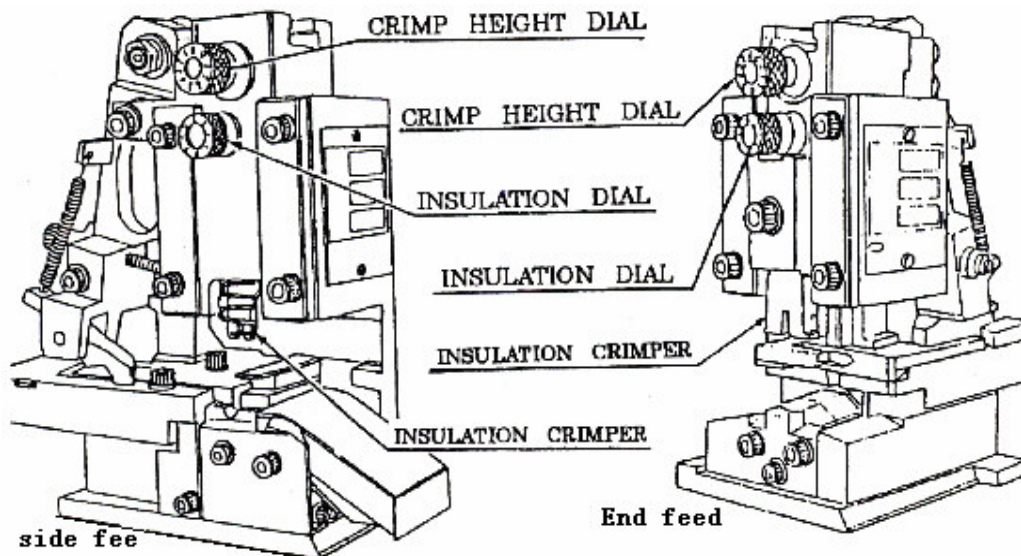

- ④ If can't regulate the proper high position, Please loose the two of bolts-M6 of RAM ADAPTER on front. Move the Ram Bolt to suited position by subsidiary tool.

Instruction of RAM BOLT

Ram bolt dial, Rotate a scale and can regulate 0.05mm from head to foot each time

After the operation of the above, and then regulate the Crimp height dial according to the wire.

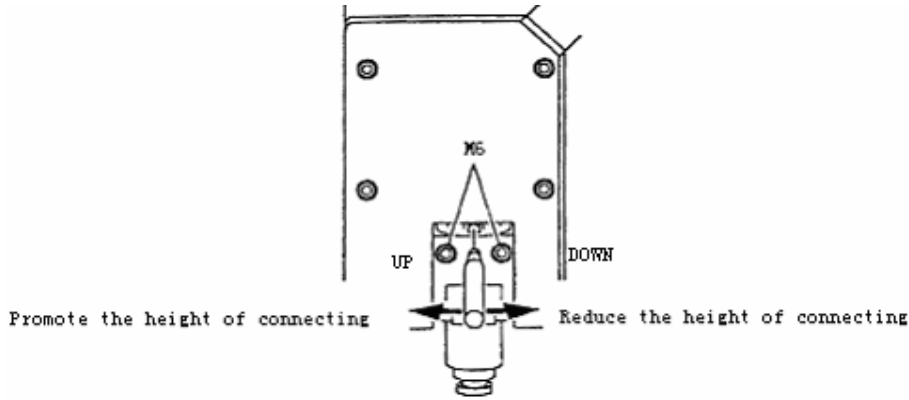

2. Adjust the height of insulation

Instruction of PVC insulation dial

1> There are 1~8 number signed on the insulation dial.

2> Raise one figure each time, the insulation highly lower 0.1mm.

- ① After Adjust the height of pressing of the core wire, please regulate the PVC height of insulation.
- ② The Operating sequence is same as Crimp height dial, When change the PVC height of insulation, pull out the crimp height dial for adjust the dial and push it to the slot.

TECHNICAL SUPPORT

For technical support, please contact us @ **(877) 589 -9422** or email at

info@smtmax.com

SMTmax

125 Business Center Drive

Unit G

Corona, CA 92880

Tel: 951-278-0720

Fax: 951-582-9422

Email: info@smtmax.com